

## Descriptions

The DW03 series product is a high integration solution for lithium-ion/polymer battery protection. DW03 contains advanced power MOSFET, high-accuracy voltage detection circuits and delay circuits.

DW03 is put into an ultra-small SOT23-5 package and only one external component makes it an ideal solution in limited space of battery pack. DW03 has all the protection functions required in the battery application including overcharging, overdischarging, overcurrent and load short circuiting protection etc. The accurate overcharging detection voltage ensures safe and full utilization charging. The low standby current drains little current from the cell while in storage. The device is not only targeted for digital cellular phones, but also for any other Li-Ion and Li-Poly battery-powered information appliances requiring long-term battery life.

## Features

- ◆ Integrate advanced power MOSFET with Equivalent of 65mΩ RDS(ON);
- ◆ Ultra-small SOT23-5 package;
- ◆ Over-temperature Protection; Overcharge Current Protection; Two-step Overcurrent Detection; Overdischarge Current; Load Short Circuiting.
- ◆ Charger detection function; 0V battery charging function; delay times are generated inside; High-accuracy voltage detection.
- ◆ Low Current Consumption; Operation Mode: 2.8μA typ; Power-down Mode: 1.5μA typ; RoHS Compliant and Lead(Pb) Free.

## Applications

One-Cell lithium-ion battery pack; Lithium-Polymer battery pack.

### Typical Application

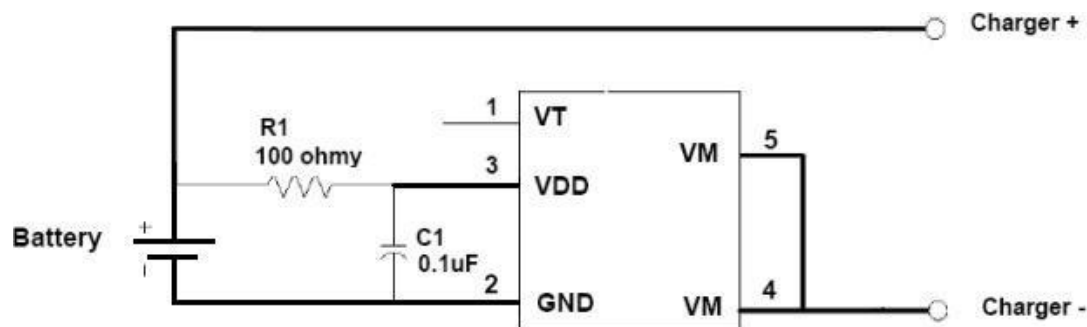

Notes :

- (1)The chip power consumption shall not exceed the maximum power consumed by the package.
- (2)This product has anti-static protection function, but do not exceed the maximum capacity of the product to withstand static electricity.

### Pinning

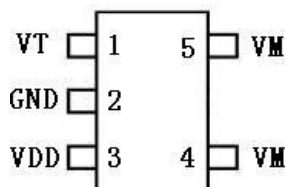

Pin Number	Pin Name	Pin Description
1	VT	Test pin
2	GND	Ground,connect the negative terminal of the battery to this pin.
3	VDD	Power Supply
4、 5	VM	The negative terminal of the charger.The internal FET switch connects this terminal to GND.

**Absolute Maximum Ratings(Ta=25°C)**

Parameter	Symbol	Value	Unit
Vpp input pin voltage	V <sub>IN</sub>	-0.3 to+6.0	V
Vm input pin voltage	V <sub>M</sub>	-6.0 to+10	V
Power Dissipation	PD	400	mW
Maximum Junction Temperature	T <sub>J</sub>	125	°C
Lead Temperature	T <sub>L</sub>	300	°C
Operating Junction Temperature	T <sub>opr</sub>	-40 to+85	°C
Storage Temperature	T <sub>stg</sub>	-55 to+150	°C
Package Thermal Resistance	R <sub>oJA</sub>	250	°C/W
	R <sub>eJc</sub>	130	°C/W
ESD	ESD	2000	V

**Electrical Characteristics (Unless specified, Ta=25°C)**

Parameter	Symbo	Test Condition	Min	Typ	Max	Unit
Overcharge Detection Voltage	V <sub>cu</sub>		4.25	4.30	4.35	V
Overcharge Release Voltage	V <sub>cL</sub>		4.05	4.10	4.15	V
Overdischarge Detection Voltage	V <sub>DL</sub>		2.30	2.40	2.50	V
Overdischarge Release Voltage	V <sub>DR</sub>		2.90	3.00	3.10	V
Charger Detection Voltage	V <sub>CHA</sub>			-0.12		V
Overdischarge Current1 Detection	I <sub>iov1</sub>	V <sub>dd</sub> =3.5V		3.0		A
Load Short-Circuiting Detection	I <sub>sHORT</sub>	V <sub>dd</sub> =3.5V		12		A
Current Consumption in Normal Operation	I <sub>oPE</sub>	V <sub>dd</sub> =3.5V,V <sub>M</sub> =0V		2.80		μA
Current Consumption in power Down	I <sub>PDN</sub>	V <sub>dd</sub> =2V,V <sub>m</sub> floating		1.50	6.0	μA
Equivalent FET on Resistance	R <sub>os</sub>	V <sub>ad</sub> =3.6V,I <sub>m</sub> =1A		65		mΩ
Over Temperature Protection	T <sub>sHD+</sub>			120		°C
Over Temperature Recovery Degree	T <sub>sHD-</sub>			100		°C
Overcharge Voltage Detection Delay Time	T <sub>cu</sub>	V <sub>Dp</sub> =3.6V~4.4V		128		ms
Overdischarge Voltage Detection Delay Time	T <sub>pL</sub>	V <sub>pp</sub> =3.6V~2.0V		32		ms
Overdischarge Current1 Detection Delay Time	T <sub>iov1</sub>	V <sub>Dp</sub> =3.6V		8.0		ms
Load Short-Circuiting Detection Delay Time	T <sub>sHORT</sub>	V <sub>Dp</sub> =3.6V		32		μs

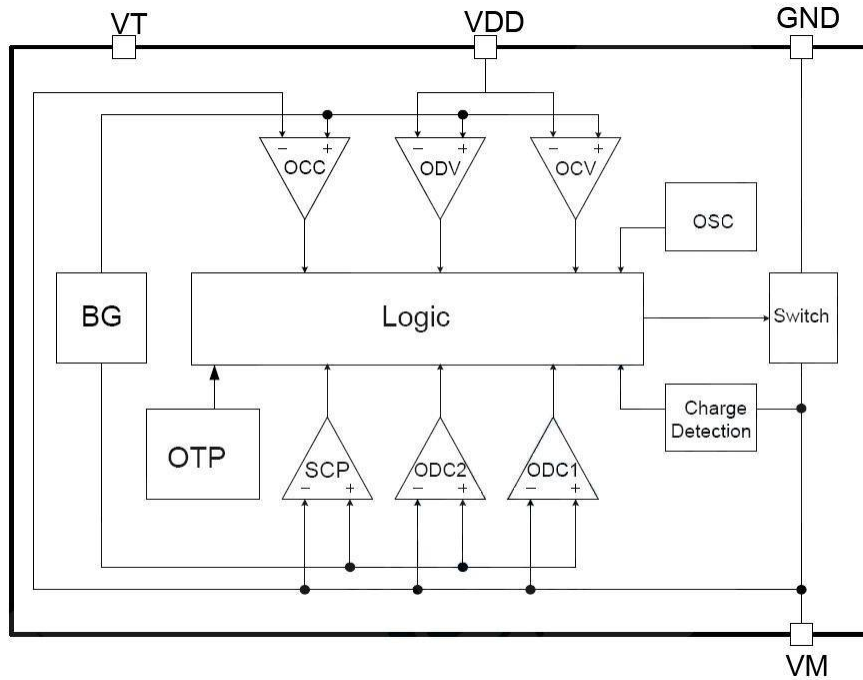
**Functionl Block Diagram**

**Functional Description**

The DW03 monitors the voltage and current of a battery and protects it from being damaged due to overcharge voltage, overdischarge voltage, overdischarge current, and short circuit conditions by disconnecting the battery from the load or charger. The peripheral circuit is very simple. The MOSFET is integrated and its RDS(ON) is as low as 65mΩ typical.

**Normal Operating mode**

If no exception condition is detected, charging and discharging can be carried out freely. This condition is called the normal operating mode.

## Overcharge Condition

When the battery voltage becomes higher than the overcharge detection voltage (VCU) during charging under normal condition and the state continues for the overcharge detection delay time (TCU) or longer, the DW03 turns the charging control FET off to stop charging. This condition is called the overcharge condition.

The overcharge condition is released in the following two cases:

(1) When the battery voltage drops below the overcharge release voltage (VCL), the DW03 turns the charging control FET on and returns to the normal condition.

(2) When a load is connected and discharging starts, the DW03 turns the charging control FET on and returns to the normal condition. The release mechanism is as follows: the discharging current flows through an internal parasitic diode of the charging FET immediately after a load is connected and discharging starts, and the VM pin voltage increases about 0.7 V (forward voltage of the diode) from the GND pin voltage momentarily. The DW03 detects this voltage and releases the overcharge condition. Consequently, in the case that the battery voltage is equal to or lower than the overcharge detection voltage (VCU), the DW03 returns to the normal condition immediately, but in the case the battery voltage is higher than the overcharge detection voltage (VCU), the chip does not return to the normal condition until the battery voltage drops below the overcharge detection voltage (VCU) even if the load is connected. In addition, if the VM pin voltage is equal to or lower than the overcurrent 1 detection voltage when a load is connected and discharging starts, the chip does not return to the normal condition.

Note: If the battery is charged to a voltage higher than the overcharge detection voltage (VCU) and the battery voltage does not drop below the overcharge detection voltage (VCU) even when a heavy load, which causes an overcurrent, is connected, the overcurrent 1 and overcurrent 2 do not work until the battery voltage drops below the overcharge detection voltage (VCU). Since an actual battery has, however, an internal impedance of several dozens of mΩ, and the battery voltage drops immediately after a heavy load which causes an overcurrent is connected, the overcurrent 1 and overcurrent 2 work. Detection of load shortcircuiting works regardless of the battery voltage.

### **Overdischarge Condition**

When the battery voltage drops below the overdischarge detection voltage (VDL) during discharging under normal condition and it continues for the overdischarge detection delay time (tDL) or longer, the DW03 turns the discharging control FET off and stops discharging. This condition is called overdischarge condition. After the discharging control FET is turned off, the VM pin is pulled up by the RVMD resistor between VM and VDD in DW03, the current of the chip is reduced to the power-down current (IPDN). This condition is called power-down condition. The VM and VDD pins are shorted by the RVMD resistor. The power-down condition is released when a charger is connected and the potential difference between VM and VDD becomes typical or higher, at this time, the FET is still off. When the battery voltage becomes the overdischarge detection voltage (VDL) or higher (see note), the DW03 turns the FET on and changes to the normal condition from the overdischarge condition. Note: If the VM pin voltage is no less than the charger detection voltage (VCHA), when the battery under overdischarge condition is connected to a charger, the overdischarge condition is released (the discharging control FET is turned on) as usual, provided that the battery voltage reaches the overdischarge release voltage (VDR) or higher.

### **Overcurrent Condition**

When the discharging current becomes equal to or higher than a specified value (the VM pin voltage is equal to or higher than the overcurrent detection voltage) during discharging under normal condition and the state continues for the overcurrent detection delay time or longer, the DW03 turns off the discharging control FET to stop discharging. This condition is called overcurrent condition. (The overcurrent includes overcurrent, or load shortcircuiting.) The VM and GND pins are shorted internally by the RVMS resistor under the overcurrent condition. When a load is connected, the VM pin voltage equals the VDD voltage due to the load. Because of the connection between the VM and the GND by the RVMS resistor, when the load is removed, the VM pin goes back to the GND potential since the VM pin is shorted to the GND pin with the RVMS resistor. Detecting that the VM pin potential is lower than the overcurrent detection voltage (VIOV1), the IC returns to the normal condition.

## Abnormal Charge Current Detection

If the VM pin voltage drops below the charger detection voltage (VCHA) during charging under the normal condition and it continues for the overcharge detection delay time (TCU) or longer, the DW03 turns the charging control FET off and stops charging. This action is called abnormal charge current detection. Abnormal charge current detection is released when the voltage difference between VM pin and GND

pin becomes higher than the charger detection voltage (VCHA) by separating the charger. Since the 0 V battery charging function has higher priority than the abnormal charge current detection function, abnormal charge current may not be detected by the product with the 0 V battery charging function while the battery voltage is low.

## Load Short-circuiting Condition

If voltage of VM pin is higher short circuiting protection voltage (VSHORT) and it continues for the tSHORT or longer, the DW03 will stop discharging and battery is disconnected from load. This status is released when voltage of VM pin is higher than short protection voltage (VSHORT), such as when disconnecting the load.

## 0V Battery Charging Function

This function enables the charging of a connected battery whose voltage is 0V by self-discharge. When connects to a charger, the discharging control FET is off and the charging current flows through the internal parasitic diode in the discharging control FET. If the battery voltage becomes equal to or higher than the overdischarge release voltage (VDL), the normal condition returns.

Notes :

- (1) Some battery providers do not recommend charging of completely discharged batteries. Please refer to battery providers before the selection of 0 V battery charging function.
- (2) The 0V battery charging function has higher priority than the abnormal charge current detection function. Consequently, a product with the 0 V battery charging function charges a battery and abnormal charge current cannot be detected during the battery voltage is low.
- (3) When a battery is connected to the IC for the first time, the IC may not enter the normal condition in which discharging is possible. In this case, set the VM pin voltage equal to the GND voltage (short the VM and GND pins or connect a charger) to enter the normal condition.

### Timing Chart

#### Overcharge And Overdischarge Detection

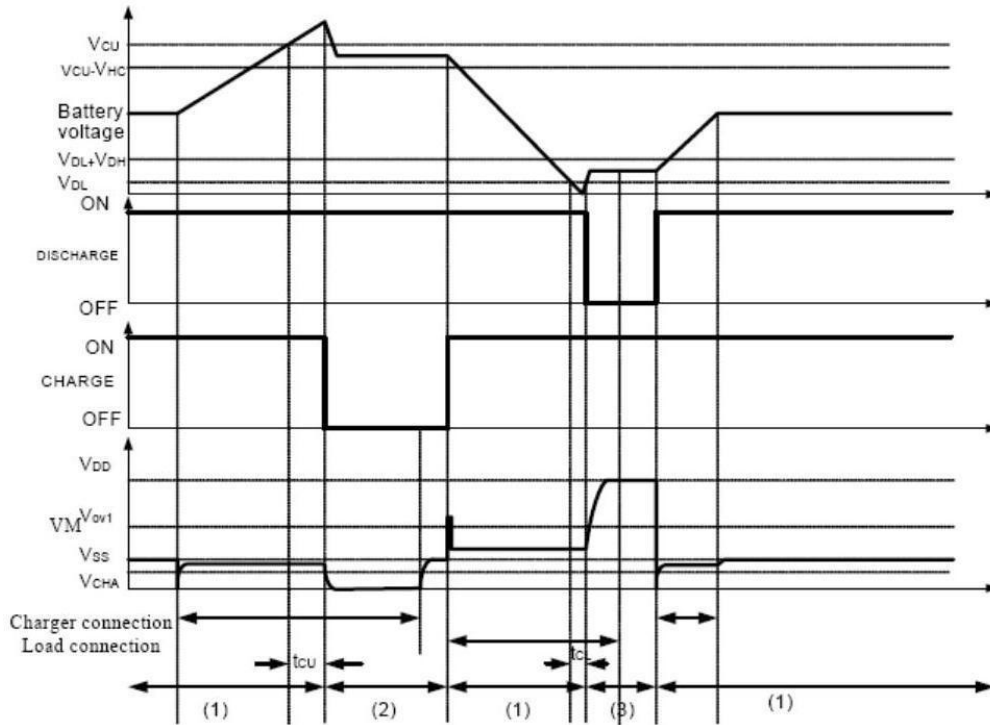

#### Overdischarge Current Detection

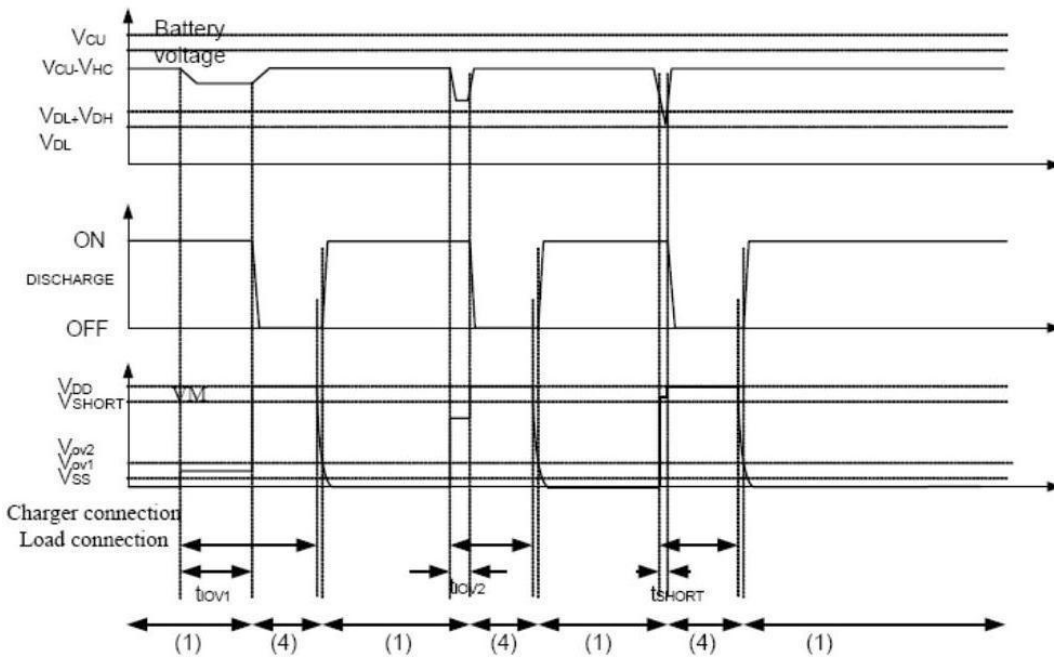



### Timing Chart

#### ChargerDetection

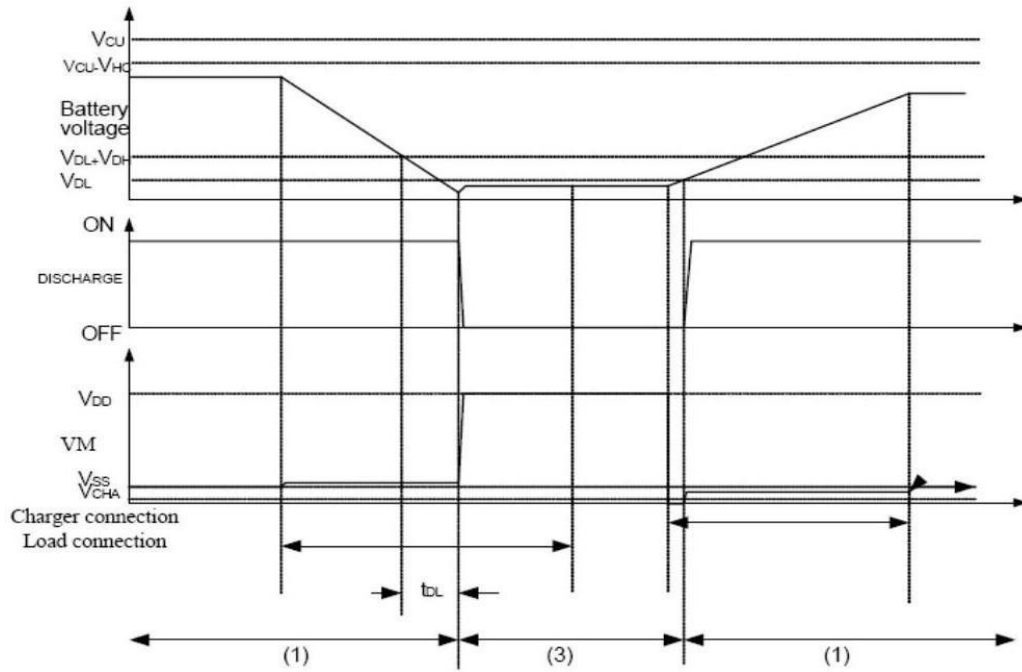

#### AbnormalChargeDetection

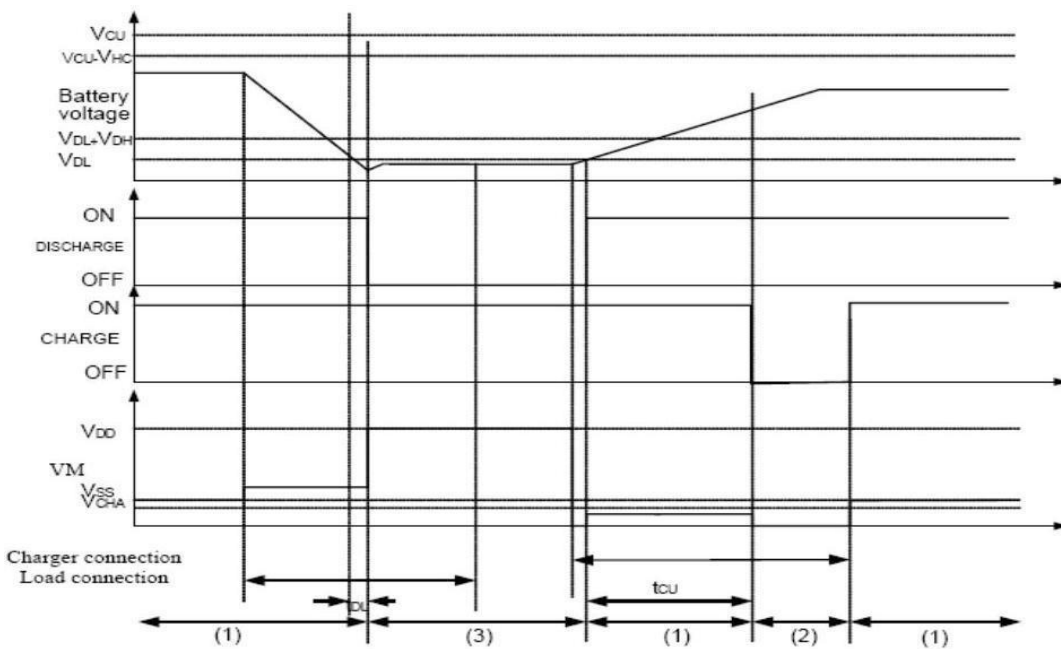

Notes: (1) Normal condition (2) Overcharge voltage condition (3) Overdischarge voltage condition (4) Overcurrent condition

Package Dimensions

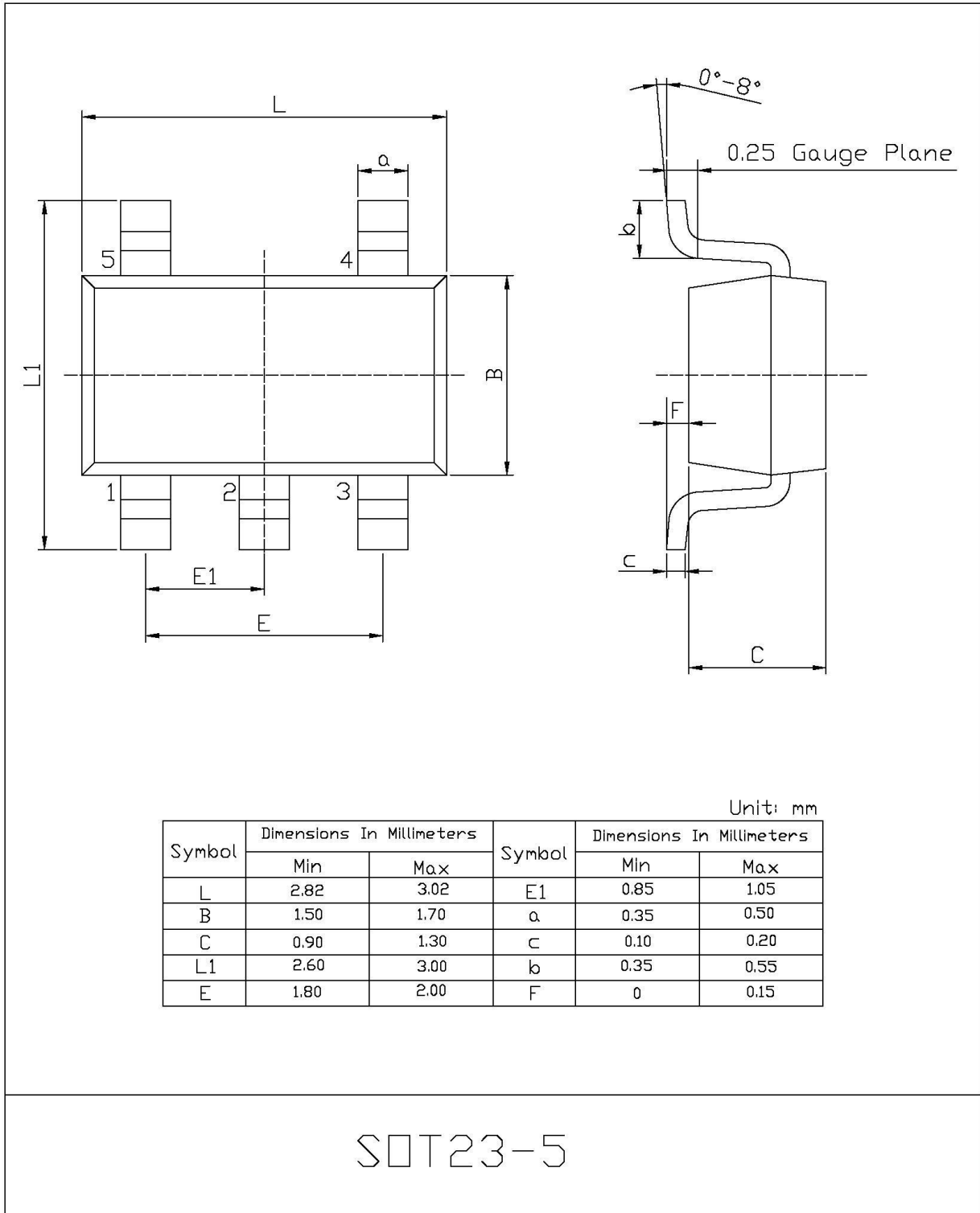

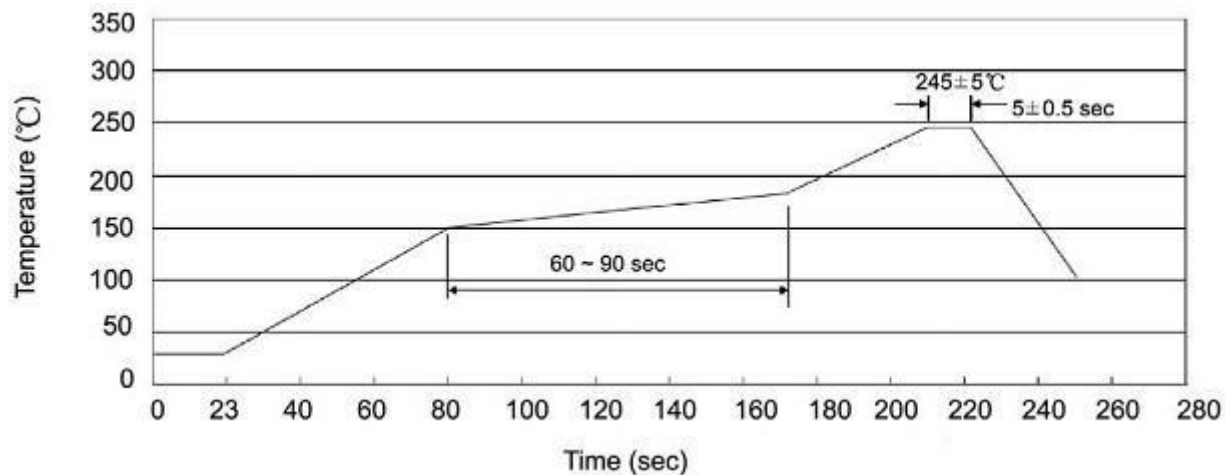
**Temperature Profile for IR Reflow Soldering(Pb-Free)**

Note:

1. Preheating: 25~150°C, Time: 60~90sec.
2. Peak Temp.: 245±5°C, Duration: 5±0.5sec.
3. Cooling Speed: 2~10°C/sec.

**Resistance to Soldering Heat Test Conditions**

Temp.: 260±5°C

Time: 10±1 sec