

Low power high sensitivity bipolar hall chip

1. Introduction

SL6103 is a low-power, high-sensitivity, bipolar Hall switch chip designed and produced using CMOS technology. Integrated within the device are a voltage regulator, Hall voltage generator, small signal amplifier, chopper stabilizer, Schmitt trigger, and CMOS output driver. This chip exhibits excellent temperature stability, strong stress resistance, and high sensitivity, operating within a voltage range of 2.7V to 5.5V. It is available in TO92S through-hole and SOT23-3L surface-mount packages, both compliant with RoHS environmental standards.



2. Features

- push-pull output
- ESD performance up to : $\pm 6\text{kV}$
- operating voltage : 2.7V~5.5V
- Micropower battery-powered applications
- Bipolar output switch

3. Fields of application

- solid state switch
- Instrumentation
- laptop
- PDA

4. Package

Type	Package	Temperature Range	Packaging
SL6103-9	TO92S	-40°C ~ 85°C	1000/bag
SL6103-3	SOT23-3L	-40°C ~ 85°C	3000/reel

5. Block diagram

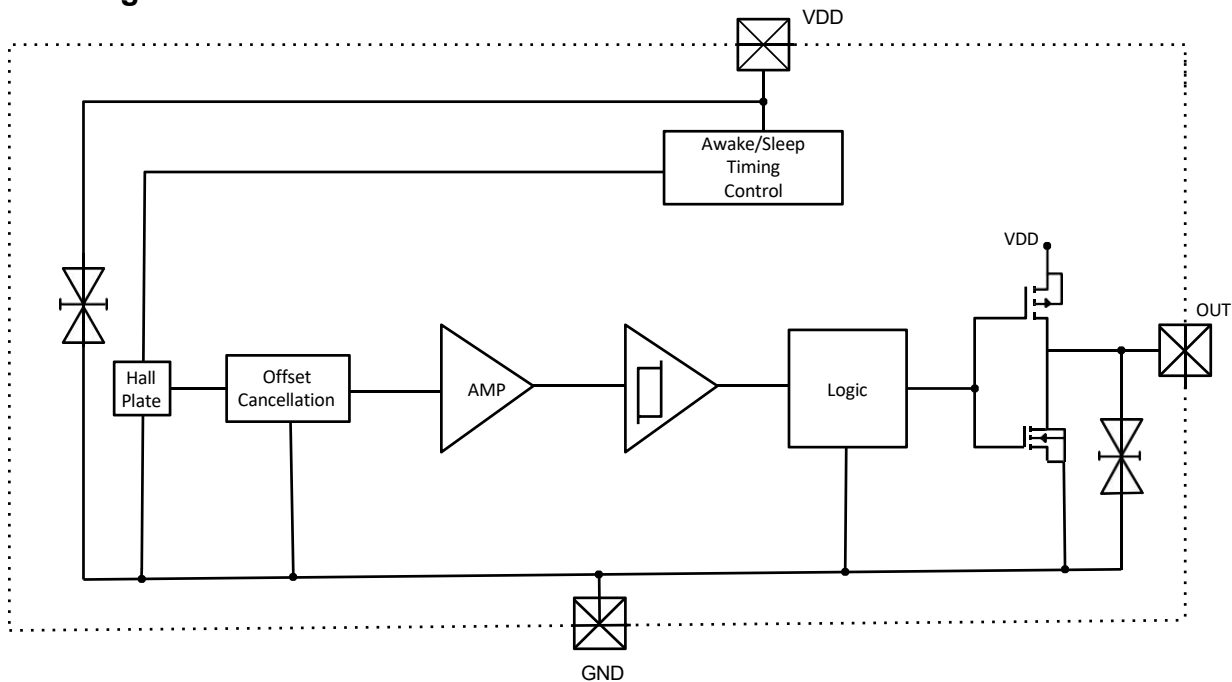

6. Pin description

Number	Name	Function
1	V _{CC}	power supply
2	GND	ground
3	V _{OUT}	output

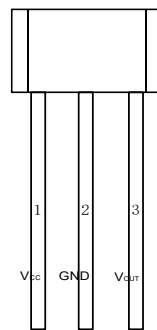

TO92S

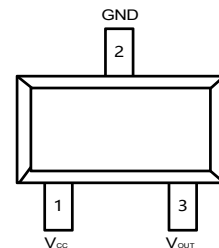

SOT23-3L

7. Application example

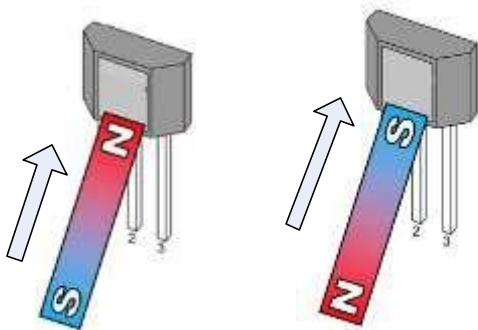

V_{OUT}=Low Level

V_{OUT}=High Level

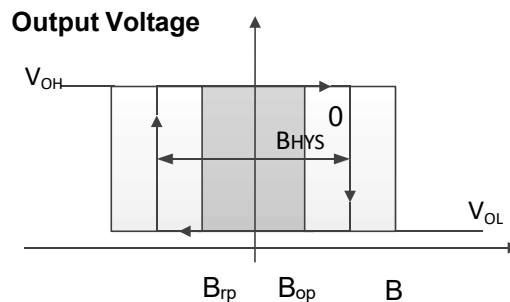

TO92S Output State

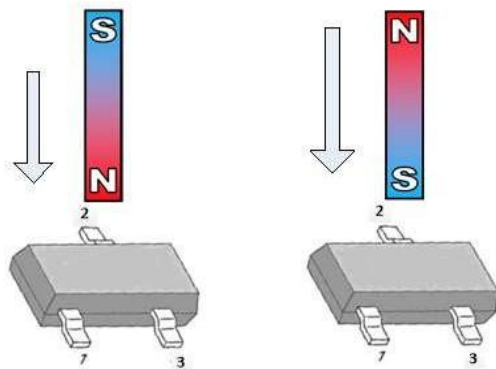
 V_{OUT} =Low Level

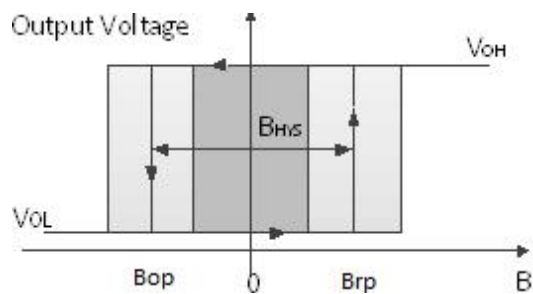
 V_{OUT} =High Level

SOT23-3L Output State

8. Limit parameters

Parameter	Notation	Numeric	Units
supply voltage	V_{CC}	6.0	V
reverse voltage	V_{CCR}	-0.3	V
output current	I_{OUT}	5	mA
output voltage	V_{OUT}	6.0	V
operating temperature range	T_A	-40~85	°C
storage temperature range	T_S	-50~150	°C

The absolute maximum rating is the chip's limit beyond which it may incur permanent damage.

9. Electrical and magnetic characteristics ($T_A=25^\circ\text{C}$, $V_{CC}=3.0\text{V}$)

Parameter	Notation	Test Conditions	Min.	Typ.	Max.	Units
Electrical Characteristics						
operating voltage	V_{CC}	at work	2.7		5.5	V
saturation voltage drop	V_{OL}	$I_{OUT}=1\text{mA}$			0.2	V
output current	I_{OUT}				3.0	mA
average power supply current	I_{DD}			0.7	1.5	mA
wake-up mode time	T_{awk}	at work		50	80	us
sleep mode time	T_p	at work		150	240	us
operating frequency	F_w			2.5		kHz
Magnetic Characteristics						
work point	B_{op}			25		Gs
release point	B_{rp}			-25		Gs
return difference	B_{hys}	$ B_{op}-B_{rp} $		50		Gs

10. Application circuit

C1=2.2uF

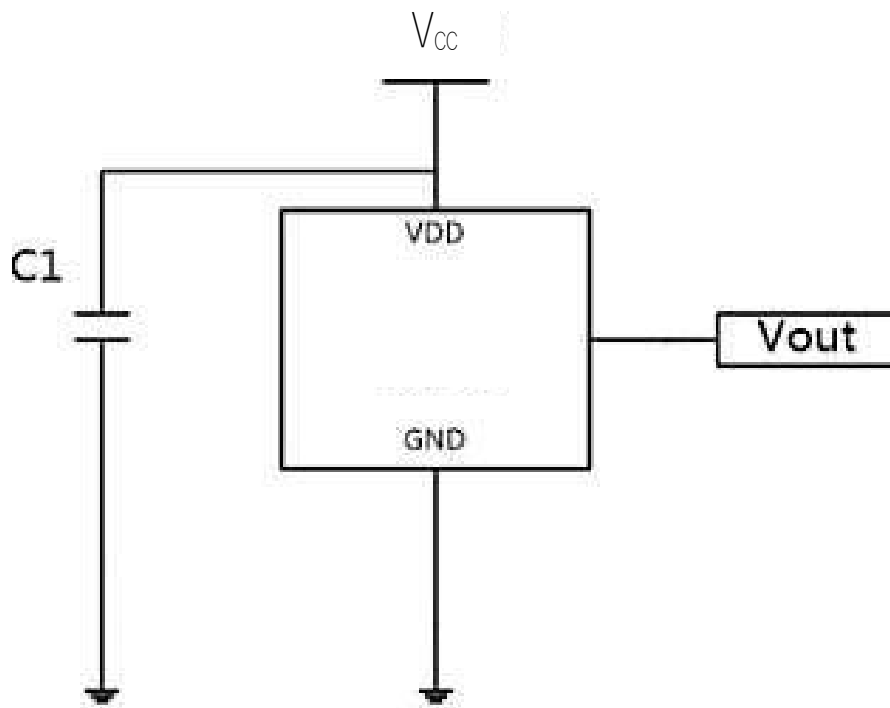

Typical Application Circuit

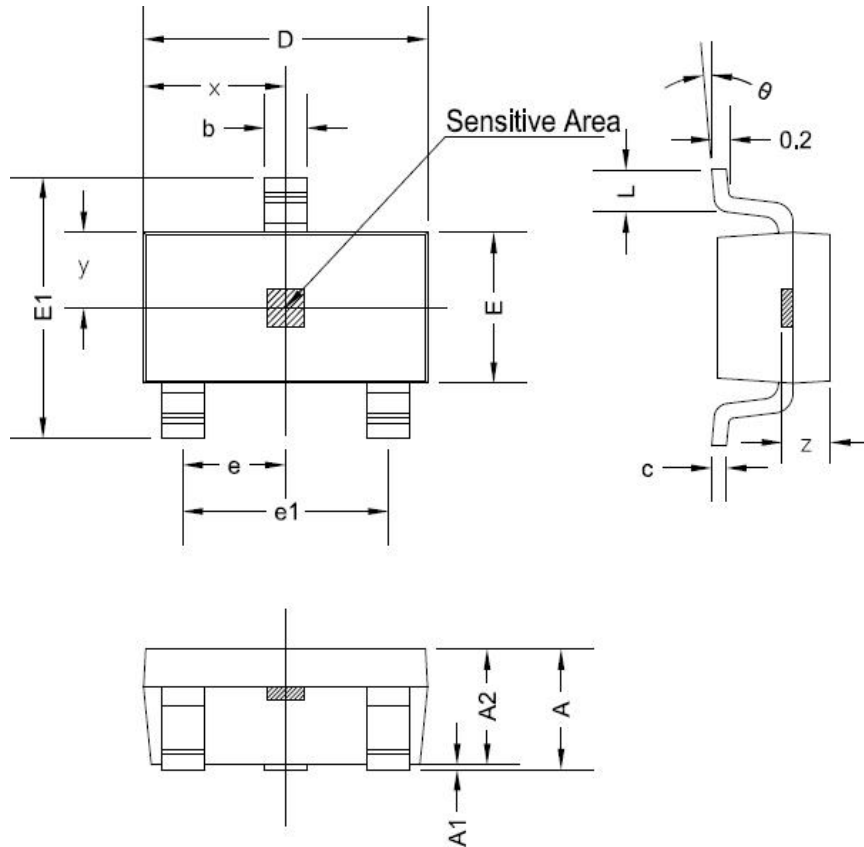
SOT23-3L Package Size

Notation	Size (mm)		Size (in inches)	
	Min.	Max.	Min.	Max.
A	1.050	1.250	0.041	0.049
A1	0.000	0.100	0.000	0.004
A2	1.050	1.150	0.041	0.045
b	0.300	0.500	0.012	0.020
c	0.100	0.200	0.004	0.008
D	2.820	3.020	0.111	0.119
E	1.500	1.700	0.059	0.067
E1	2.650	2.950	0.104	0.116
e	0.950TYP		0.037TYP	
e1	1.800	2.000	0.071	0.079
L	0.300	0.600	0.012	0.024
x	1.460TYP		0.057TYP	
y	0.800TYP		0.032TYP	
z	0.600TYP		0.024TYP	
θ	0°	8°	0°	8°

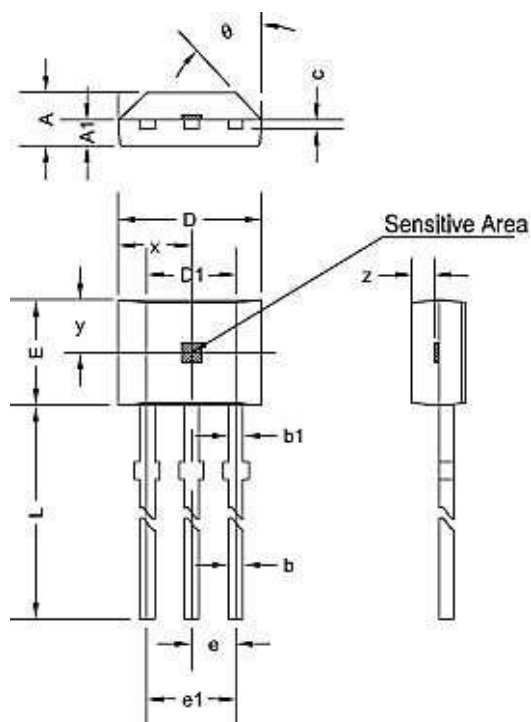
11. Package Information
T092S Package Size

Notation	Size (mm)		Size (in inches)	
	Min.	Max.	Min.	Max.
A	1.420	1.670	0.056	0.066
A1	0.660	0.860	0.026	0.034
b	0.350	0.560	0.014	0.022
b1	0.400	0.550	0.016	0.022
C	0.360	0.510	0.014	0.020
D	3.900	4.200	0.154	0.165
D1	2.970	3.270	0.117	0.129
E	2.900	3.280	0.114	0.129
e	1.270TYP		0.050TYP	
e1	2.440	2.640	0.096	0.104
L	13.500	15.500	0.531	0.610
x	2.025TYP		0.080TYP	
y	1.545TYP		0.061TYP	
z	0.500TYP		0.020TYP	
θ	45°TYP		45°TYP	