

Ultra-low power 1.5V-4.5V wide voltage range 200KSPS-1MSPS single-channel 12-bit analog-to-digital converter (ADC).

Features

- 1.5V-4.5V single power supply, automatic shutdown
- Ultra-low power consumption (typical)
 - 0.26mW (3.3V, 100KSPS)
 - 0.11mW (2.5V, 100KSPS)
 - 0.04mW (1.6V, 100KSPS)
- Maximum sampling rate 200 KSPS (1.5V-3.0V)
- Maximum sampling rate 1 MSPS (3.0V-4.5V)
- Maximum error ± 1.5 LSB INL, ± 1.5 LSB DNL
- 0- V_{DD} unipolar single-channel input
- SPI/DSP/MICROWIRE™/QSPI™ compatible
- serial interface schematic
- 6-pin SOT-23 package

Application

- Battery powered systems
- Medical electronic equipment
- Standalone data acquisition equipment
- Remote data acquisition equipment

Description

1. The power supply voltage range is specified to be 1.5V-4.5V.
 2. High speed and low power consumption. Up to 1 MSPS, the typical power consumption is 0.05mW at an operating voltage of 1.8V and 100KSPS.
 3. Convenient power supply/serial clock speed management. The conversion rate is determined by the serial clock, and the conversion time can be reduced by increasing the serial clock speed. Automatic power-off after conversion can reduce the average power consumption when the power is off.
- SL7466 is a 12-bit ADC (Analog-to-Digital Converter) chip, that is, an analog-to-digital converter, with the basic characteristics of ultra-low power consumption, small size, unipolarity, and single-ended input. SL7466 is designed with advanced process and technology, and has a wide voltage operating range:
- When powered by a single power supply of 1.5V-3.0V, the sampling rate can reach up to 200 KSPS (compatible with similar chips);
- When powered by a single power supply of 3.0V-4.5V, the sampling rate can reach up to 1 MSPS.
- SL7466 adopts 6-pin SOT-23 package and has an operating temperature range of -40 to 85.
- SL7466 can replace AD7466 pin-to-pin, and its dynamic power consumption is less than 1/2, which significantly extends the battery working time.

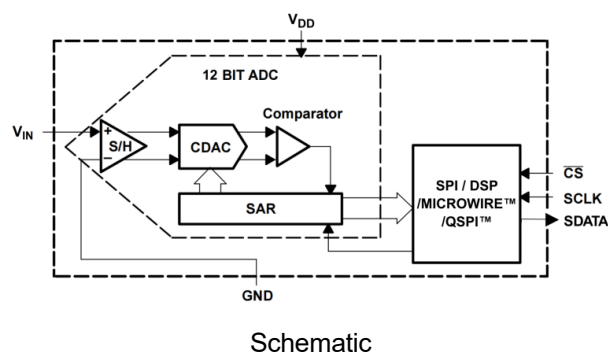

Packaging diagram

1. Main technical parameters

1.5V-4.5V single power supply
 12-bit resolution, no missing codes
 Differential nonlinearity error (DNL): ± 1.5 LSB
 Integral nonlinearity error (INL): ± 1.5 LSB
 Signal-to-noise ratio distortion (SNR): 71.25 dB @ 30 KHz
 Total harmonic distortion (THD): -84 dB @ 30 KHz
 Unipolar single channel input, 0 V to V_{DD} range

Maximum sampling rate 200 KSPS (1.5V-3.0V)
 Maximum sampling rate 1 MSPS (3.0V-4.5V)
 SPI/DSP/MICROWIRE™/QSPI™ compatible serial interface
 No pipeline cycle delay
 Automatic shutdown
 6-pin SOT-23 package

Power comparison with AD7466(T=25°C):

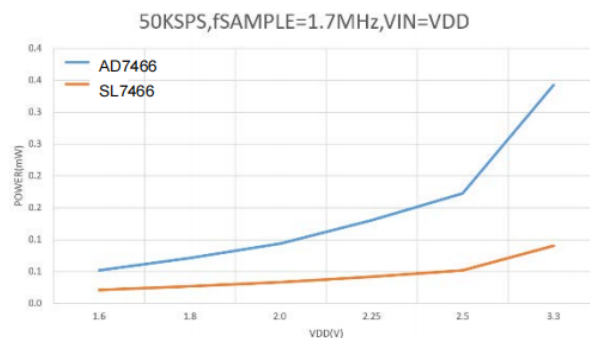
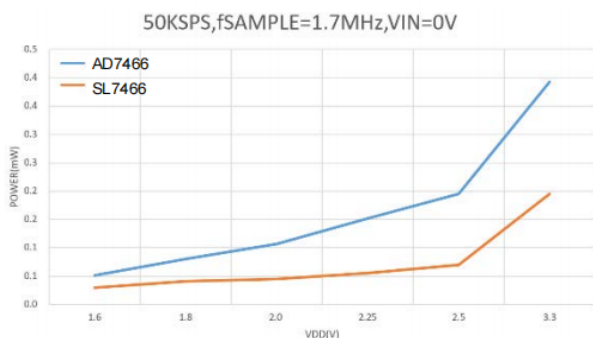
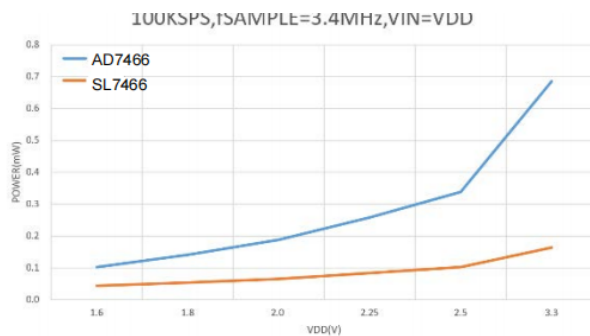
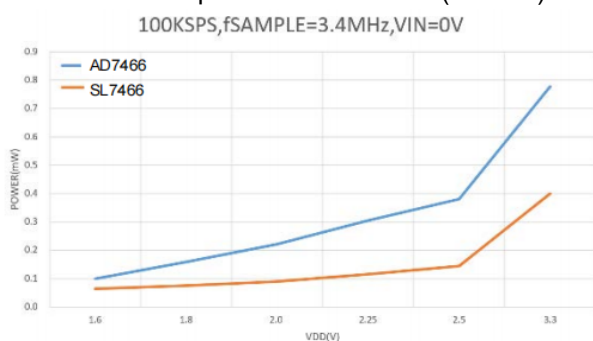

2. Pin configuration

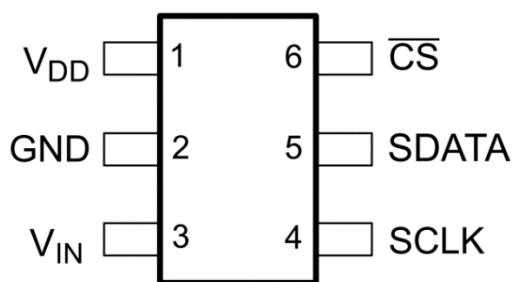

Pin diagram

Pin		Description
Name	Serial number	
V_{DD}	1	Power supply input. The V_{DD} range of the device is from 1.5V to 4.5V.
GND	2	Analog input signal ground. All analog and digital signals are referenced to this pin.
V_{IN}	3	Unipolar analog signal input. Input range is 0 to V_{DD} .
SCLK	4	Serial clock input. Clock is use to output data and source of the conversion clock.
SDATA	5	This is serial data output of the conversion result. The serial stream is MSB first.
CS	6	Chip select signal, active low, select SCLK, start conversions and frame out data.

3. Typical connection

See the figure below for a typical connection circuit of the SL7466. The 1.8 V power supply should come from a stable power supply device such as an LDO. A 0.1 μF coupling capacitor is required between the VDD pin and the GND pin of the SL7466. The capacitor should be as close as possible to the pin of the SL7466.

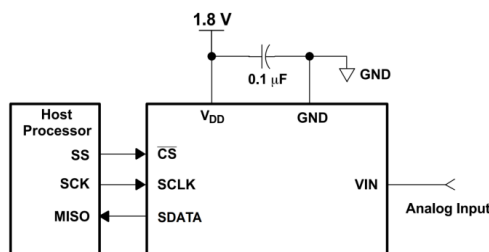

Circuit connection diagram

4. Timing diagram

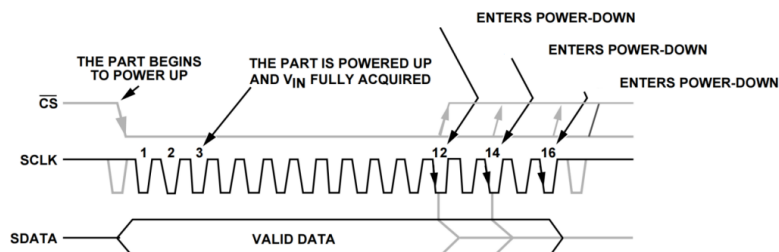

Timing diagram

A conversion cycle is initiated when the CS pin is pulled low and the serial clock SCLK signal is provided. After the CS falling edge, the time between the 3rd falling edge of SCLK (T sample) is used to sample the input signal. After the 3rd SCLK falling edge, the ADC enters the hold mode/conversion cycle (T_{convert}) and begins the digitization process of the sampled input signal. At the 16th falling edge of SCLK, SDO enters the high impedance state and the conversion cycle ends.

5. Conversion results

The SL7466 outputs 12 bits of converted data after 4 leading zeros, and these codes are in standard binary format.

Description	Analog input voltage	Digital output system	
		Binary	Hexadecimal
SL7466(12 bit)			
Least Significant Bit (LSB)	$V_{\text{op}}/4096$		
Full Scale	$V_{\text{Dp}}-1\text{LSB}$	111111111111	FFF
Mid Scale	$V_{\text{pp}}/2$	100000000000	800
Mid Scale-1LSB	$V_{\text{pp}}/2-1\text{LSB}$	011111111111	7FF
Zero	0V	000000000000	000

After power-up, the SL7466 has no specific initialization requirements, but the first conversion will not produce valid results. To set the SL7466 to a known state, CS is changed from low to high after VDD stabilizes during power-up. This puts the SL7466 in auto-shutdown mode, and the serial data output (SDO) is high impedance. The next time the CS pin is lowered and the serial clock SCLK signal is provided, the conversion can be performed normally and the result can be output.

6. Packaging diagram

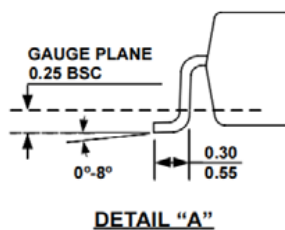
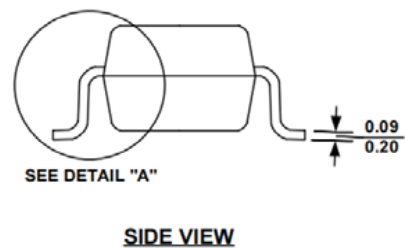
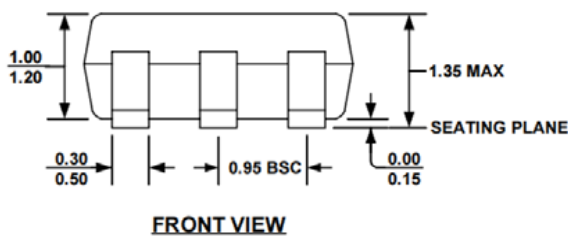
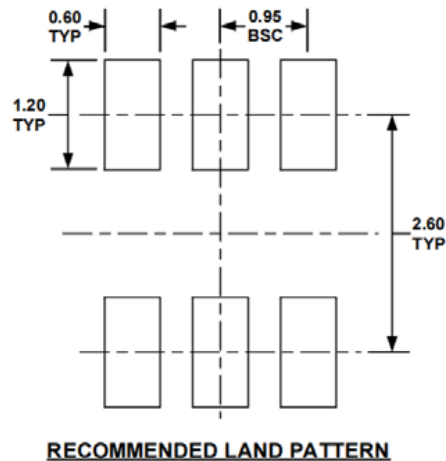
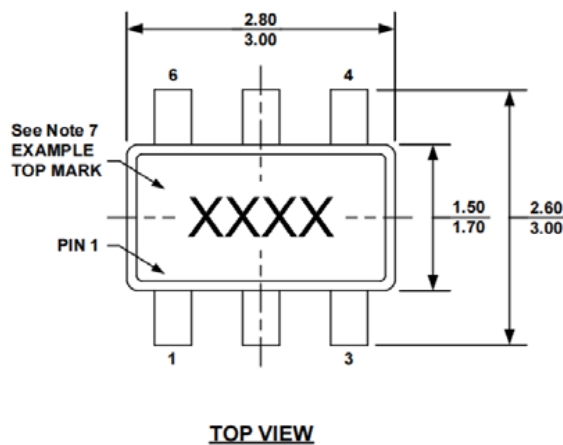

NOTE:

- 1) ALL DIMENSIONS ARE IN MILLIMETERS.
- 2) PACKAGE LENGTH DOES NOT INCLUDE MOLD FLASH, PROTRUSION OR GATE BURR.
- 3) PACKAGE WIDTH DOES NOT INCLUDE INTERLEAD FLASH OR PROTRUSION.
- 4) LEAD COPLANARITY (BOTTOM OF LEADS AFTER FORMING) SHALL BE 0.10 MILLIMETERS MAX.
- 5) DRAWING CONFORMS TO JEDEC MO-178, VARIATION AB.
- 6) DRAWING IS NOT TO SCALE.
- 7) PIN 1 IS LOWER LEFT PIN WHEN READING TOP MARK FROM LEFT TO RIGHT, (SEE EXAMPLE TOP MARK)

7. Precautions

1. Unpacked ICs and tube-packed ICs must be stored in a dry cabinet with a humidity of <20% R.H.
2. Components must be stored in anti-static packaging bags after storage and access.
3. Anti-static damage: The device is an electrostatic sensitive device. Adequate anti-static measures should be taken during transmission, assembly, and testing.
4. Users should conduct an appearance inspection before use. The bottom, sides, and surroundings of the circuit must be bright before welding. If oxidation occurs, the circuit can be treated by deoxidation means. After the treatment, the circuit must be welded within 12 hours.