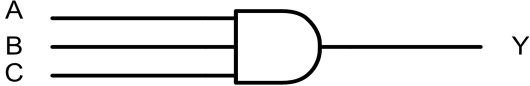

## Dual 2-Input Positive-AND Gate

1 Features	2 Application
<ul style="list-style-type: none"> <li>- Supports 5V <math>V_{CC}</math> operation</li> <li>- Inputs accept voltages to 5.5 V</li> <li>- Provides down translation to <math>V_{CC}</math></li> <li>- Low power consumption, 10-<math>\mu</math>A Max <math>I_{CC}</math></li> <li>- <math>\pm 24</math>-mA output drive at 3.3 V</li> <li>- <math>I_{off}</math> supports live insertion, partial-power-down mode, and back drive protection</li> </ul>	<ul style="list-style-type: none"> <li>- Active noise cancellation (ANC)</li> <li>- Barcode scanner</li> <li>- Blood pressure monitor</li> <li>- CPAP machine</li> <li>- Fingerprint biometrics</li> <li>- HVAC: heating, ventilating, and air conditioning</li> <li>- Network-attached storage (NAS)</li> <li>- Server motherboard and PSU</li> <li>- Software defined radio (SDR)</li> <li>- Video communications system</li> </ul>

3 Description	Circuit Diagram
<p>This single 3-input positive-AND gate is designed for 1.65-V to 5.5-V <math>V_{CC}</math> operation.</p> <p>The 74LVC1G11 performs the Boolean function <math>Y=A \cdot B \cdot C</math> or <math>Y=\overline{A+B+C}</math> in positive logic.</p> <p>The 74LVC1G11 device is fully specified for partial-power-down applications using <math>I_{off}</math>. The <math>I_{off}</math> circuitry disables the outputs, preventing damaging current backflow through the device when it is powered down.</p>	 <p>The diagram shows a standard 3-input AND gate symbol. It has three horizontal input lines on the left labeled 'A', 'B', and 'C' from top to bottom. The gate is a D-shaped symbol with a flat left side and a curved right side. A single horizontal output line extends from the right side of the gate, labeled 'Y'.</p>

## 4 Device Summary, Pin and Packages

Table. 4-1. Device Summary<sup>(1)</sup>

Serial Name	Part Name	Package	MSL <sup>(2)</sup>	Package Qty
74LVC1G11	74LVC1G11S6	SOT23-6	3	Tape and Reel,3000
	74LVC1G11C6	SC70-6	3	Tape and Reel,3000

(1) For all available packages, please contact product sales.

(2) MSL, The Moisture Sensitivity Level rating according to the JEDEC industry standard classifications.

**4 Device Summary, Pin and Packages(continued)**

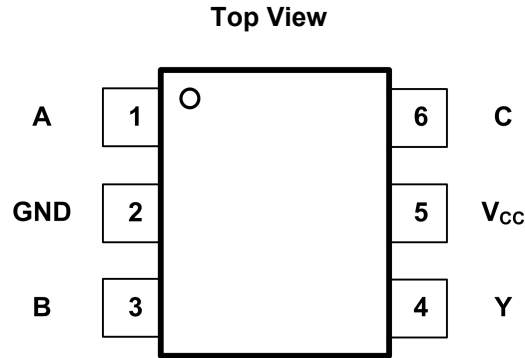

**Fig.4-1. 74LVC1G11: S6(SOT23-6) Package  
74LVC1G11: C6(SC70-6) Package**

**Table. 4-2. Pin Definition**

Pin		Type	Description
Name	S6 C6		
A	1	I	Data Input
GND	2	-	Ground
B	3	I	Data Input
Y	4	O	Data Output
V <sub>cc</sub>	5	-	Supply Voltage
C	6	I	Data Input

## 5 Voltage, Temperature, ESD and Thermal ratings

### 5.1 Absolute Maximum Ratings<sup>(1)</sup>

Parameters		Min	Max	Unit
V <sub>CC</sub>	Supply voltage range	-0.5	6.5	V
V <sub>I</sub>	Input voltage range	-0.5	6.5	V
V <sub>O</sub>	Voltage range applied to any output in the high-impedance or power-off state <sup>(2)</sup>	-0.5	6.5	V
V <sub>O</sub>	Voltage range applied to any output in the high or low state <sup>(2)</sup>	-0.5	V <sub>CC</sub> +0.5	V
I <sub>IK</sub>	Input clamp current	V <sub>I</sub> <0	-50	mA
I <sub>OK</sub>	Output clamp current	V <sub>O</sub> <0	-50	mA
I <sub>O</sub>	Continuous output current		±50	mA
	Continuous current through V <sub>CC</sub> or GND		±100	mA
T <sub>J</sub>	Junction temperature under bias		150	°C
T <sub>stg</sub>	Storage temperature range	-55	150	°C

(1) Stresses beyond those listed under Absolute Maximum Ratings may cause permanent damage to the device. These are stress ratings only, and functional operation of the device at these or any other conditions beyond those indicated under Recommended Operating Conditions is not implied. Exposure to absolute-maximum-rated conditions for extended periods may affect device reliability.

(2) The input negative-voltage and output voltage ratings may be exceeded if the input and output current ratings are observed.

### 5.2 ESD Ratings

ESD		Value	Unit	
V(ESD)	Electrostatic Discharge	Human-body model (HBM) <sup>(1)</sup>	8 K	V
		Charged-Device Model (CDM) <sup>(2)</sup>	2 K	V

(1) JEDEC document JEP155 states that 500-V HBM allows safe manufacturing with a standard ESD control process.

(2) JEDEC document JEP157 states that 250-V CDM allows safe manufacturing with a standard ESD control process.

## 5 Voltage, Temperature, ESD and Thermal ratings(continued)

### 5.3 Recommended Operating Conditions

Over operating free-air temperature range (unless otherwise noted)

Symbol	Parameter	Min	Max	Unit
V <sub>CC</sub>	Supply Voltage	1.65	5.5	V
V <sub>IH</sub>	High-Level Input Voltage	VCC=1.65V to 1.95V	0.65×VCC	V
		VCC=2.3V to 2.7V	1.7	
		VCC=3V to 3.6V	2	
		VCC=4.5V to 5.5V	0.7×VCC	
V <sub>IL</sub>	Low-Level Input Voltage	VCC=1.65V to 1.95V	0.35×VCC	V
		VCC=2.3V to 2.7V	0.7	
		VCC=3V to 3.6V	0.8	
		VCC=4.5V to 5.5V	0.3×VCC	
V <sub>I</sub>	Input Voltage	0	5.5	V
V <sub>O</sub>	Output Voltage	0	VCC	V
I <sub>OH</sub>	High-Level Output Current	VCC=1.65V	-4	mA
		VCC=2.3V	-8	
		VCC=3V	-16	
		VCC=4.5V	-24	
		VCC=4.5V	-32	
I <sub>OL</sub>	Low-Level Output Current	VCC=1.65V	4	mA
		VCC=2.3V	8	
		VCC=3V	16	
		VCC=3V	24	
		VCC=4.5V	32	
Δt/Δv	Input Transition Rise or Fall Rate	VCC=1.8V±0.15V, 2.5V±0.2V	20	ns/V
		VCC=3.3V±0.3V	10	
		VCC=5V±0.5V	5	
TA	Operating Free-Air Temperature	-40	125	°C

### 5.4 Thermal Information

Package Type	θ <sub>JA</sub>	θ <sub>JC</sub>	Unit
SOT23-6	196	81	°C/W
SC70-6	178	98	°C/W

## 6 Electrical Specifications<sup>(1)</sup>

Over recommended operating free-air temperature range (unless otherwise noted)

Parameter	Test Conditions	V <sub>CC</sub>	-40°C to 85°C			-40°C to 125°C			Unit
			Min	Typ	Max	Min	Typ	Max	
V <sub>OH</sub>	I <sub>OH</sub> =-100 μA	1.65 V to 5.5 V	V <sub>CC</sub> -0.1			V <sub>CC</sub> -0.1			V
	I <sub>OH</sub> =-4 mA	1.65 V	1.2			1.2			
	I <sub>OH</sub> =-8 mA	2.3 V	1.9			1.9			
	I <sub>OH</sub> =-16 mA	3 V	2.4			2.4			
	I <sub>OH</sub> =-24 mA		2.3			2.3			
	I <sub>OH</sub> =-32 mA	4.5 V	3.8			3.8			
V <sub>OL</sub>	I <sub>OL</sub> =100 μA	1.65 V to 5.5 V			0.1			0.1	V
	I <sub>OL</sub> =4 mA	1.65 V			0.45			0.45	
	I <sub>OL</sub> =8 mA	2.3 V			0.3			0.3	
	I <sub>OL</sub> =16 mA	3 V			0.4			0.4	
	I <sub>OL</sub> =24 mA				0.55			0.55	
	I <sub>OL</sub> =32 mA	4.5 V			0.55			0.55	
I <sub>I</sub>	A or B or C Inputs	V <sub>I</sub> =5.5 V or GND			±5			±5	μA
I <sub>off</sub>		V <sub>I</sub> or V <sub>O</sub> =5.5 V			±10			±10	μA
I <sub>CC</sub>		V <sub>I</sub> =5.5 V or GND, I <sub>O</sub> =0	1.65 V to 5.5 V		10			10	μA
ΔI <sub>CC</sub>		One Input at V <sub>CC</sub> -0.6 V, Other Inputs at V <sub>CC</sub> or GND	3 V to 5.5 V		500			500	μA
C <sub>i</sub>		V <sub>I</sub> =V <sub>CC</sub> or GND	3.3 V		4			4	pF

(1) All unused digital inputs of the device must be held at V<sub>CC</sub> or GND to ensure proper device operation.

## 6 Electrical Specifications (continued)

### Switching Characteristics, CL=15 pF

Over recommended operating free-air temperature range (unless otherwise noted)

Parameter	From (Input)	To (Output)	-40°C to 85°C								Unit
			V <sub>CC</sub> =1.8 V ± 0.15 V		V <sub>CC</sub> =2.5 V ± 0.2 V		V <sub>CC</sub> =3.3 V ± 0.3 V		V <sub>CC</sub> =5 V ± 0.5 V		
			Min	Max	Min	Max	Min	Max	Min	Max	
tpd	A or B or C	Y	2.6	15.2	1.6	5.6	1.2	4.1	1	3.1	ns

Over recommended operating free-air temperature range, CL=30 pF or 50 pF (unless otherwise noted)

Parameter	From (Input)	To (Output)	-40°C to 85°C								Unit
			V <sub>CC</sub> =1.8 V ± 0.15 V		V <sub>CC</sub> =2.5 V ± 0.2 V		V <sub>CC</sub> =3.3 V ± 0.3 V		V <sub>CC</sub> =5 V ± 0.5 V		
			Min	Max	Min	Max	Min	Max	Min	Max	
tpd	A or B or C	Y	2.9	17.2	1.4	6.2	1.3	4.9	1	3.5	ns

Over recommended operating free-air temperature range, CL=30 pF or 50 pF (unless otherwise noted)

Parameter	From (Input)	To (Output)	-40°C to 125°C								Unit
			V <sub>CC</sub> =1.8 V ± 0.15 V		V <sub>CC</sub> =2.5 V ± 0.2 V		V <sub>CC</sub> =3.3 V ± 0.3 V		V <sub>CC</sub> =5 V ± 0.5 V		
			Min	Max	Min	Max	Min	Max	Min	Max	
tpd	A or B or C	Y	2.9	20	1.4	7.8	1.3	6.2	1	4.6	ns

### Operating Characteristics

T<sub>A</sub>=25°C

	Parameter	Test Conditions	V <sub>CC</sub> =1.8 V	V <sub>CC</sub> =2.5 V	V <sub>CC</sub> =3.3 V	V <sub>CC</sub> =5 V	Unit
			Typ	Typ	Typ	Typ	
Cpd	Power Dissipation Capacitance	f=10 MHz	18	19	20	23	pF

### 7 Typical Characteristics

Over recommended operating free-air temperature range, CL=30 pF or 50 pF (unless otherwise noted)

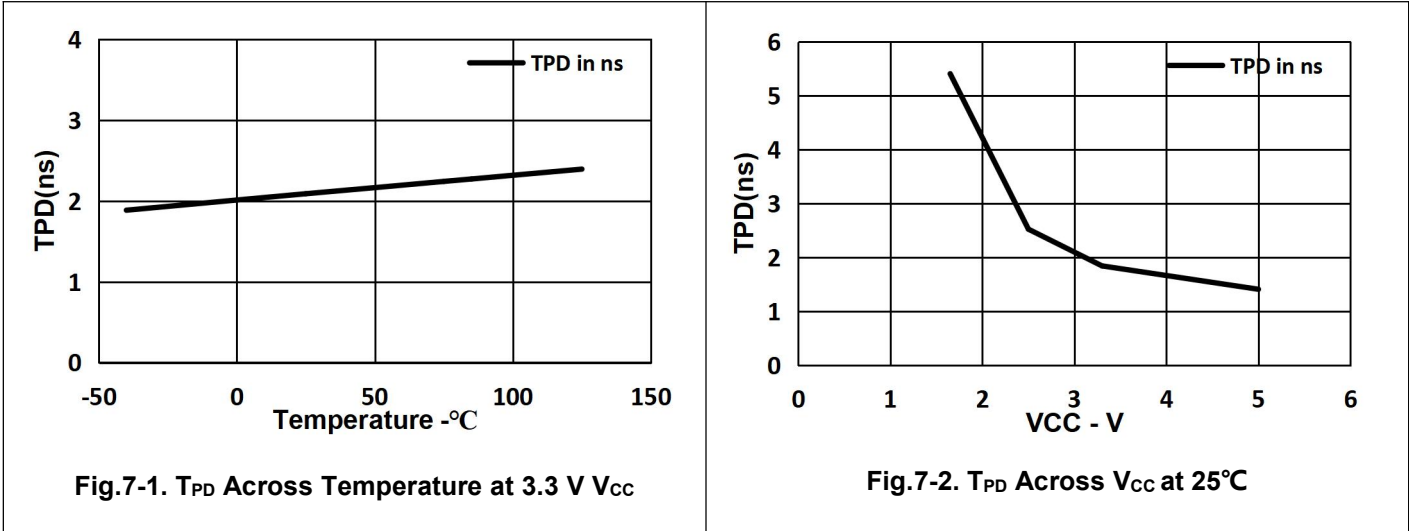



## 8 Parameter Measurement Information

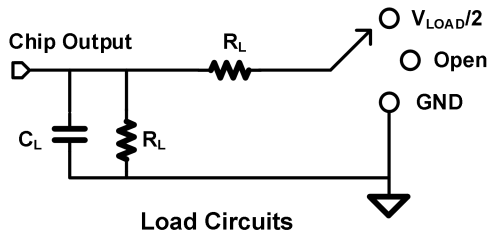

TEST	S1
$T_{PHL}/T_{PLH}$	OPEN
$T_{PLZ}/T_{PZL}$	$V_{LOAD}$
$T_{PHZ}/T_{PZH}$	GND

$V_{CC}$	INPUTS		$V_M$	$V_{LOAD}$	$C_L$	$R_L$	$V_{\Delta}$
	$V_i$	$T_r/T_f$					
$1.8V \pm 0.15V$	$V_{CC}$	$\leq 2ns$	$V_{CC}/2$	$2 \times V_{CC}$	15pF	1M $\Omega$	0.15V
$2.5V \pm 0.15V$	$V_{CC}$	$\leq 2ns$	$V_{CC}/2$	$2 \times V_{CC}$	15pF	1M $\Omega$	0.15V
$3.3V \pm 0.15V$	3V	$\leq 2.5ns$	1.5V	6V	15pF	1M $\Omega$	0.3V
$5V \pm 0.15V$	$V_{CC}$	$\leq 2.5ns$	$V_{CC}/2$	$2 \times V_{CC}$	15pF	1M $\Omega$	0.3V

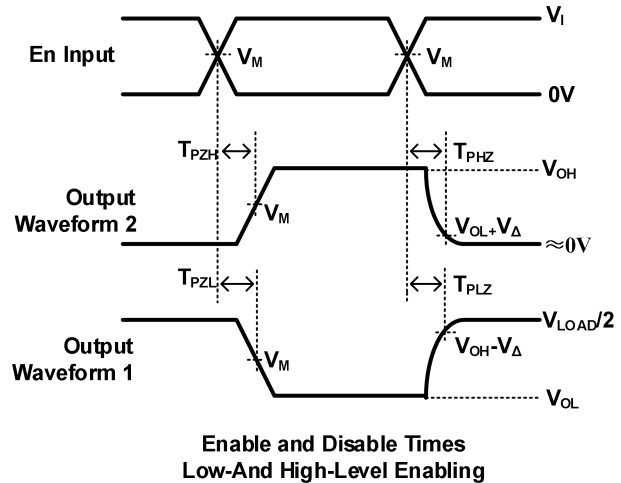
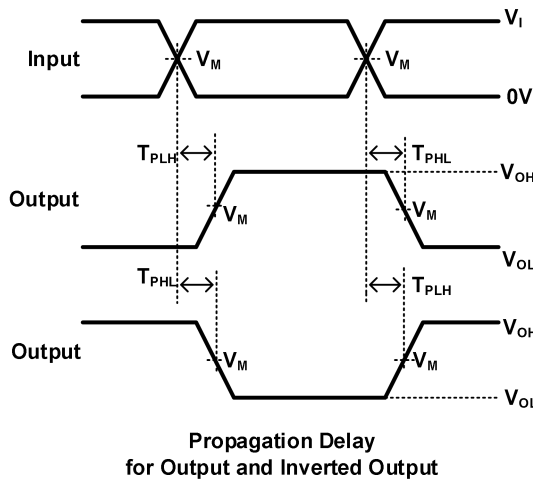
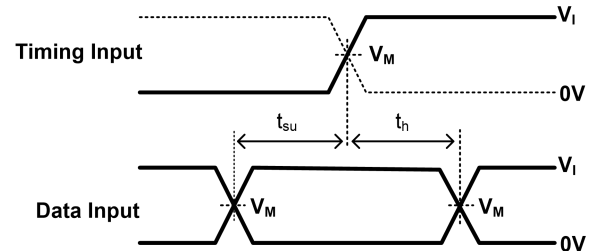
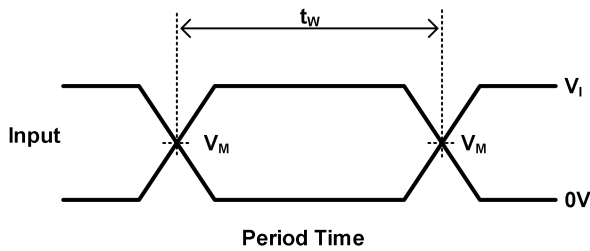

Notes: A. C includes probe and jig capacitance.

B. Waveform 1 is for an output with internal conditions such that the output is low, except when disabled by the output control. Waveform 2 is for an output with internal conditions such that the output is high, except when disabled by the output control.

C. All input pulses are supplied by generators having the following characteristics: PRR 10 MHz, Z=50.

D. The outputs are measured one at a time, with one transition per measurement.

E.  $t_{PLZ}$  and  $t_{PHZ}$  are the same as  $t_{dis}$ .

F.  $t_{PZL}$  and  $t_{PZH}$  are the same as  $t_{en}$ .

G.  $t_{PLH}$  and  $t_{PHL}$  are the same as  $t_{pd}$ .

H. All parameters and waveforms are not applicable to all device.

## 8 Parameter Measurement Information (Continued)

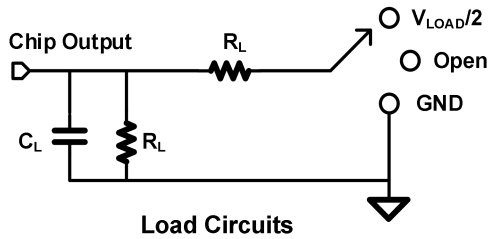

TEST	S1
$T_{PHL}/T_{PLH}$	OPEN
$T_{PLZ}/T_{PZL}$	$V_{LOAD}$
$T_{PHZ}/T_{PZH}$	GND

$V_{CC}$	INPUTS		$V_M$	$V_{LOAD}$	$C_L$	$R_L$	$V_{\Delta}$
	$V_i$	$T_r/T_f$					
$1.8V \pm 0.15V$	$V_{CC}$	$\leq 2ns$	$V_{CC}/2$	$2 \times V_{CC}$	30pF	1k $\Omega$	0.15V
$2.5V \pm 0.15V$	$V_{CC}$	$\leq 2ns$	$V_{CC}/2$	$2 \times V_{CC}$	30pF	500 $\Omega$	0.15V
$3.3V \pm 0.15V$	3V	$\leq 2.5ns$	1.5V	6V	50pF	500 $\Omega$	0.3V
$5V \pm 0.15V$	$V_{CC}$	$\leq 2.5ns$	$V_{CC}/2$	$2 \times V_{CC}$	50pF	500 $\Omega$	0.3V

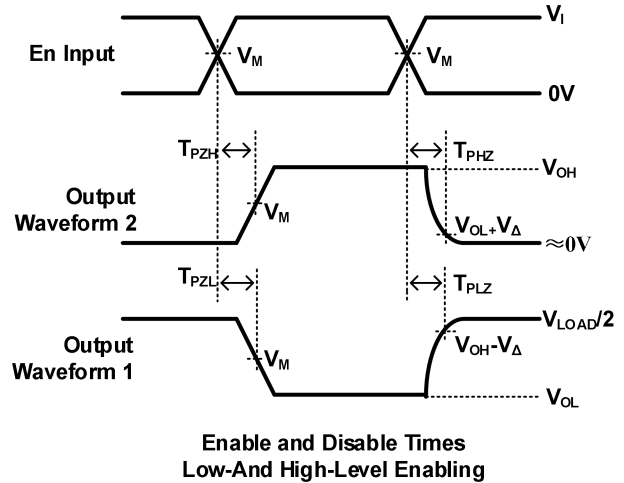
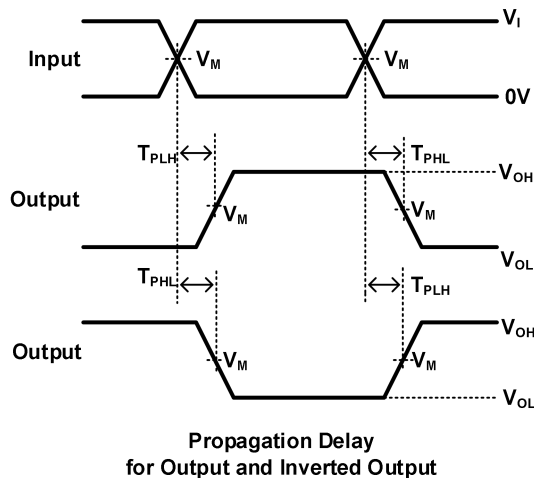
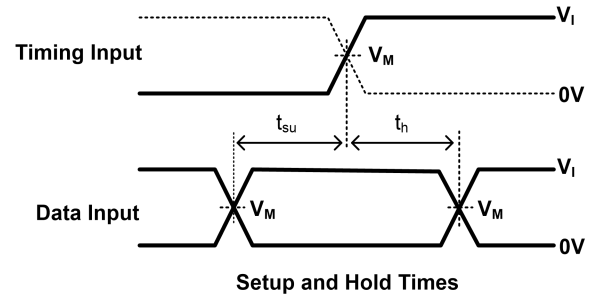
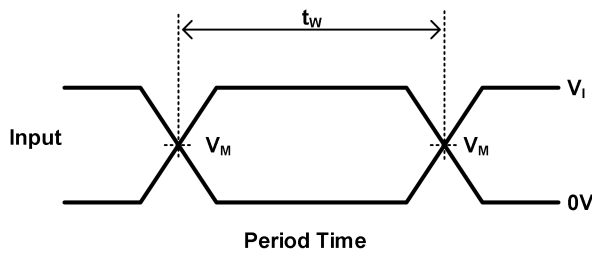

Notes: A. C includes probe and jig capacitance.

B. Waveform 1 is for an output with internal conditions such that the output is low, except when disabled by the output control. Waveform 2 is for an output with internal conditions such that the output is high, except when disabled by the output control.

C. All input pulses are supplied by generators having the following characteristics: PRR 10 MHz, Z=50.

D. The outputs are measured one at a time, with one transition per measurement.

E.  $t_{PLZ}$  and  $t_{PZH}$  are the same as  $t_{dis}$ .

F.  $t_{PZL}$  and  $t_{PZH}$  are the same as  $t_{en}$ .

G.  $t_{PLH}$  and  $t_{PHL}$  are the same as  $t_{pd}$ .

H. All parameters and waveforms are not applicable to all device.

## 9 Detailed Description

### 9.1 Overview

This 3-input AND gate is designed for 1.65-V to 5.5-V  $V_{CC}$  operation. The 74LVC1G11 device features a three-input AND gate. The output state is determined by eight patterns of 3-bit input. All inputs can be connected to  $V_{CC}$  or GND. This device is fully specified for partial-power-down applications using  $I_{off}$ . The  $I_{off}$  circuitry disables the outputs, preventing damaging current backflow through the device when it is powered down.

### 9.2 Functional Block Diagram

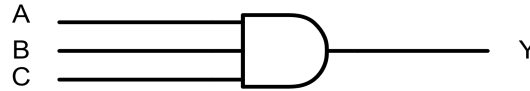

**Fig.9 -1.Functional Block Diagram**

### 9.3 Feature Description

- Wide operating voltage range.
- Operates from 1.65 V to 5.5 V.
- Allows down voltage translation.
- Inputs accept voltages to 5.5 V.
- $I_{off}$  feature allows voltages on the inputs and outputs, when  $V_{CC}$  is 0 V.

### 9.4 Device Functional Modes

Input			Output
A	B	C	Y
H	H	H	H
L	X	X	L
X	L	X	L
X	X	L	L

## 10 Application note

### 10.1 Application Information

The 74LVC1G11 device offers logical AND configuration for many design applications. This example describes basic power sequencing using the AND gate configuration. Power sequencing is often used in applications that require a processor or other delicate device with specific voltage timing requirements in order to protect the device from malfunctioning. In the application below, the power-good signals from the supplies tell the MCU to continue an operation.

### 10.2 Typical Application

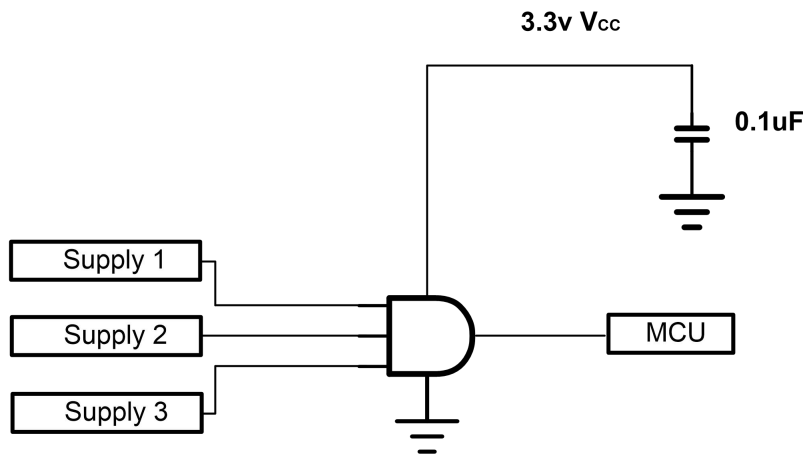

**Fig.10-1. Typical Application Diagram**

## 11 Package Outline Dimension

SOT23-6

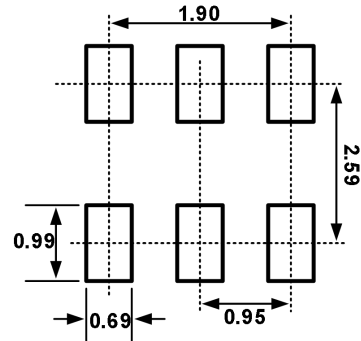
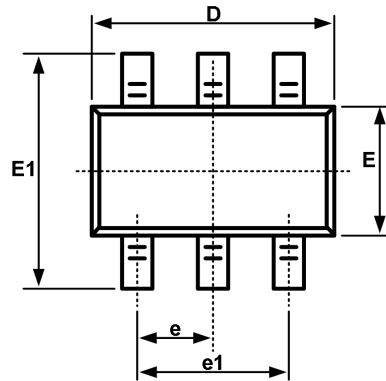

Recommended Land Pattern (Unit: mm)

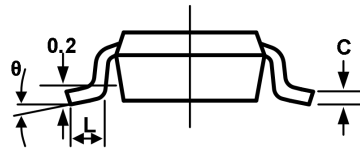
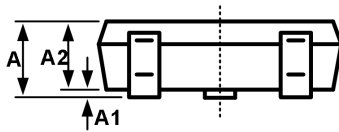

Symbol	Dimensions In Millimeters		Dimensions In Inches	
	Min	Max	Min	Max
A	1.050	1.250	0.041	0.049
A1	0.000	0.100	0.000	0.004
A2	1.050	1.150	0.041	0.045
b	0.300	0.500	0.012	0.020
c	0.100	0.200	0.004	0.008
D	2.820	3.020	0.111	0.119
E	1.500	1.700	0.059	0.067
E1	2.650	2.950	0.104	0.116
e	0.950BSC		0.037BSC	
e1	1.800	2.000	0.071	0.079
L	0.300	0.600	0.012	0.024
$\theta$	0°	8°	0°	8°

## 11 Package Outline Dimension(continued)

SC70-6

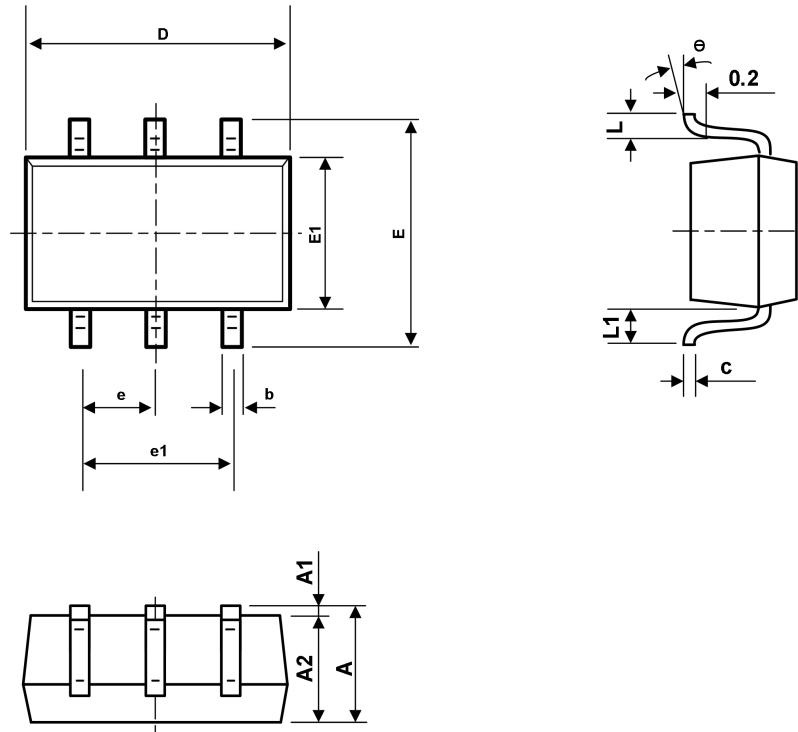

Symbol	Dimension In Millimeters		Dimensions In Inches	
	Min	Max	Min	Max
A	0.900	1.100	0.035	0.043
A1	0.000	0.100	0.000	0.004
A2	0.900	1.000	0.035	0.039
b	0.150	0.350	0.006	0.014
c	0.110	0.175	0.004	0.007
D	2.000	2.200	0.079	0.087
E	2.150	2.450	0.085	0.096
E1	1.150	1.350	0.045	0.053
e	0.650TYP		0.026TYP	
e1	1.200	1.400	0.047	0.055
L	0.260	0.460	0.010	0.018
L1	0.525REF		0.021REF	
e	$0^\circ$	$8^\circ$	$0^\circ$	$8^\circ$

## 12 Tape and Reel Information

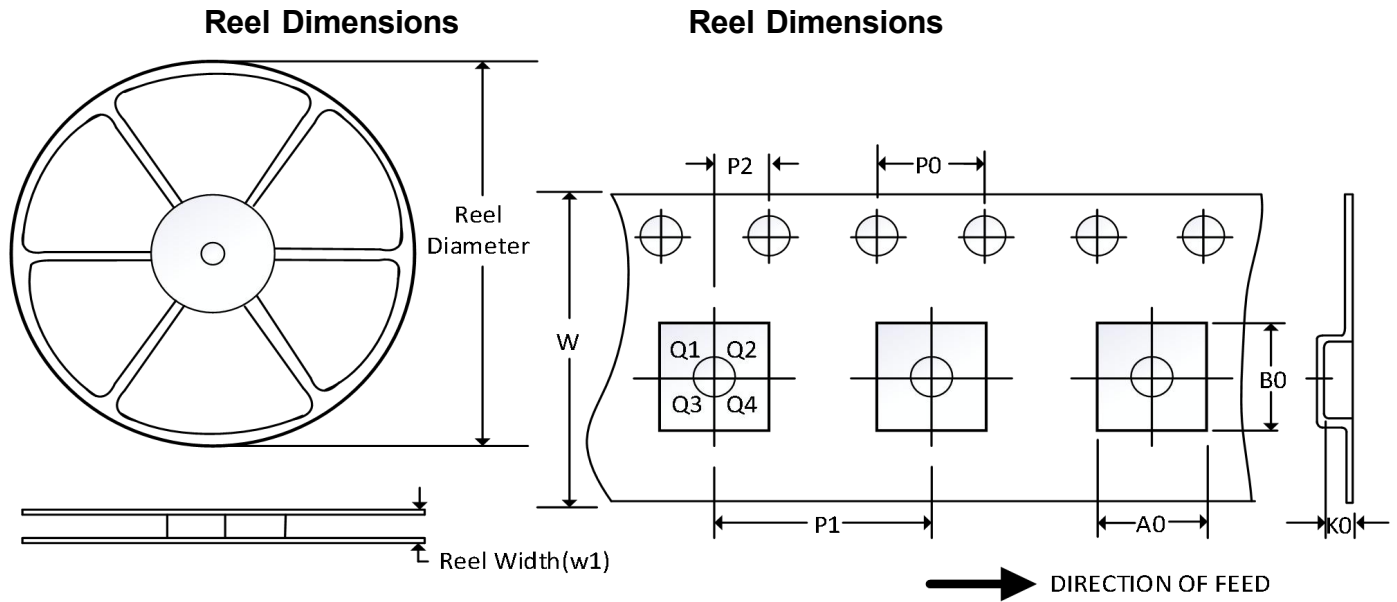

NOTE: The picture is only for reference. Please make the object as the standard.

### Key Parameter List of Tape and Reel

Package Type	Reel Diameter	Reel Width(mm)	A0 (mm)	B0 (mm)	K0 (mm)	P0 (mm)	P1 (mm)	P2 (mm)	W (mm)	Pin1 Quadrant
SOT23-6	7"	9.5	3.17	3.23	1.37	4.0	4.0	2.0	8.0	Q3
SC70-6	7"	9.5	2.40	2.50	1.20	4.0	4.0	2.0	8.0	Q3

NOTE:

1. All dimensions are nominal.
2. Plastic or metal protrusions of 0.15mm maximum per side are not included.